

Final Diploma

FD2 Drafting of Specifications

Specimen Question Paper

For first examination in October 2025

10:00 to 14:25 UK British Summer Time (GMT + 1 hour)

Examination time: 4 hours 25 minutes plus 10 minutes upload time

The 4 hours 25 minutes is allocated as follows:

10 minutes – Downloading and printing the question paper;

4 hours – Answering the questions;

15 minutes – Three screen breaks of 5 minutes each.

At 14.25 you MUST immediately stop answering the questions. You then have **10 minutes** in which to upload your Answer document to the PEBX system.

You MUST upload your Answer document to the PEBX system by 14.35. After 14.35 you will not be able to upload it and your examination will be void.

INSTRUCTIONS TO CANDIDATES

1. The whole assessment task is to be attempted.
2. The marks to be awarded are shown at the end of the assessment task.
3. The total number of marks available for this paper is 100.
4. You must use the Answer document for your answers.
5. Do not attempt to change the font style, font size, font colour, line spacing or any other preset formatting.
6. Start each part of your answer on a new page. Press the Control key and the Enter key simultaneously to begin a new page.
7. Do not state your name anywhere in the answers.
8. This question paper consists of **7 sheets**, including this sheet, and comprises:
 - Task (1 sheet)
 - Document A – Client letter (2 sheets)
 - Document B – Client drawings (3 sheets)

AT THE END OF THE EXAMINATION

9. Save your Answer document to your hard drive and follow the instructions for uploading your document onto the PEBX system.

Assessment task

Your client sends you the letter (Document A) regarding a new idea.

You have to prepare a complete patent specification that is ready for filing at the UK Intellectual Property Office. The specification should be drafted with a view to obtaining a UK patent.

Note the following:

- a) You should assume that the client's description of the prior art in the field is complete.
- b) You should not make use of any other prior art or special knowledge that you may have of the subject matter concerned.
- c) You should also assume that the client's description of the device and its operation is accurate, i.e. that the device works as described.

Allocation of marks

1.	Introduction and Statements of Invention	23 marks
2.	Specific Description and Abstract	22 marks
3.	Independent Claims	24 marks
4.	Dependant Claims	31 marks
	Total:	100 marks

Document A Client Letter

Dear Patent Attorney

Wooden pallets are cheap and plentiful, and millions are in use globally every day. They are typically made from three to six planks 2 of wood arranged in the same lengthways direction forming an upper face 3 on which you can place or stack goods which you want to transport.

5 There are around three to six planks 2 making a lower face 4, generally parallel to the planks 2 of the upper face 3. The faces 3, 4 are separated with thicker wood beams 5 which create sides to the pallet. A pallet is shown in Figure 1. The planks 2 are nailed to the beams 5 which makes them easy to repair, and thanks to the beams 5 there is space 6 between the faces 3, 4 which allows the forks of forklift trucks to be inserted, to allow the pallet 1 to be
10 lifted and carried around with ease. Which means you can load items on the upper face 3 and carry them with ease. Pallets are made to an agreed international standard to ensure things that carry them, such as lorries and containers for cargo ships, can carry a known number of them, the standard requiring a pallet to be 120cm long, 120cm wide, and sides a maximum of 20cm high.

15 Over time, wood can warp (meaning it twists), usually because it gets wet or carries too heavy a load too often, or get damaged through misuse. While planks 2 or beams 5 can be replaced, over time, replacing them stops being effective, and warped or damaged pallets risk a load being unbalanced, and when goods need to be tightly packed into lorries and the like, you cannot afford to have them not on substantially flat bases. And a warped or
20 damaged face may well not be substantially flat. Usually, users simply visually inspect pallets and can see if damage or warping is too great. But that approach is not scientific, so pallets with life left in them can be disposed of too soon, or sometimes they are kept for too long. Sometimes if they think a pallet is twisted, warped or damaged, one user will stand on a corner of a pallet, while another looks to see if any of the other corners are raised from a flat level surface 7. If they think there is too big a gap from the floor, they will dispose of the
25 pallet. More recently, people have been using simple triangular door wedges 8, and with a user standing on a corner, another tries to push the wedge 8 under a different corner. If it goes under the pallet too far, the pallet is too warped. "Too far" means either, the wedge goes to or beyond a threshold marking made by a user part way up the angled surface of the
30 wedge - meaning the marking cannot be seen, or the whole wedge 8 can travel under the pallet. This is shown in Fig 2. But this isn't consistent, so I've made a device to address the problem which can take the whole pallet if need be. See Fig 3. A spirit level is a tool for checking if an item is level. The spirit level comprises a tube part filled with a thick liquid leaving a bubble in it and there are marks on the tube. When the spirit level is held against a
35 level item, the bubble will sit between the marks.

The pallet is inserted to a frame 9. A frame 9 is a term known to people who work with
40 pallets, and comprises a large flat surface 10 on to which a pallet 1 can be placed. Around one corner of the surface 10 there is a clamp 11, which winds down and secures a corner of the pallet 1. The frame 9 is about the same size as a conventional pallet, so with one corner clamped one user can inspect the two corners connected to the clamped one, and see if the edge of the pallet deflects away from the flat line of the frame, which shows if the pallet is warped. If it is too warped, so that there is too much deflection away from that flat line of the frame, the pallet can be sent for repair or thrown away. To make sure the amount of deflection considered is consistent, at a different corner to the clamped one there is an
45 upright 12 at 90 degrees to the surface 10. On this there is a marker 13 which acts as a visual indicator of deflection, which the user can move up and down as they need and lock in

Document A Client Letter

position, as different users will have different tolerances, and this makes the level of deflection easy to see. Further, this measuring means can be a wedge 8 similar to the known door wedge, to which a user can add one or more threshold markings. This further helps one user see how much deflection there is. There can be more than one releasable
5 securing means at different corners. The frame 9 needs to be light so one person can use it, but strong so it does not warp or deflect itself. Manufacturing it from a substantially rigid material helps. Clamps have low maintenance requirements.

The user needs some assurance the frame is not itself warped and is in good order, or they may be comparing a warped pallet with a warped frame. It's useful to have a few spirit and
10 or laser levels which help act as alignment means 14 to check the frame. At least two of either are needed really. Of course, the user can use a laser level to help measure the edge of a pallet too, to help see if it is warped. Ideally a frame needs to be big enough to take a whole face of a pallet so that a user can potentially check more than one corner at a time. A frame that takes three corners of a pallet would work well too. A laser level is a laser source
15 and distal target, they are installed at known points on a level surface and provided the laser hits the target a user can be sure the surface they are on is level.

Importantly, to use the device, a user takes a pallet, inserts it into the frame, and releasably secures one corner. They then use measuring means to check the deflection of one or more edges or corners of the pallet compared to the flat surface. Sensibly, they would then take
20 the pallet out, turn it through perhaps 90 degrees, or more, and check a different corner. If one edge of a pallet is curved, as is shown in Figure 4 some measuring means would not show deflection, which is of course wrong. For example, with Figure 4, a wedge would not go under the corner of the pallet being measured. The user could of course flip the pallet over, then re-secure the pallet at the same or a different corner. With the same pallet
25 inserted but when turned over as in Figure 5, you can clearly see there is deflection along that edge of the pallet at a different corner, and you could imagine a wedge would go a long way under the corner - perhaps the whole way. Steel or composite are easily available and largely rigid materials.

I am on my way to show this to a group of prospective buyers at a public fair. They own
30 many warehouses and use several thousands of pallets every day. I don't know if they'll want to buy my invention yet, so I want to limit costs and don't want to pay any additional fees over the bare minimum.

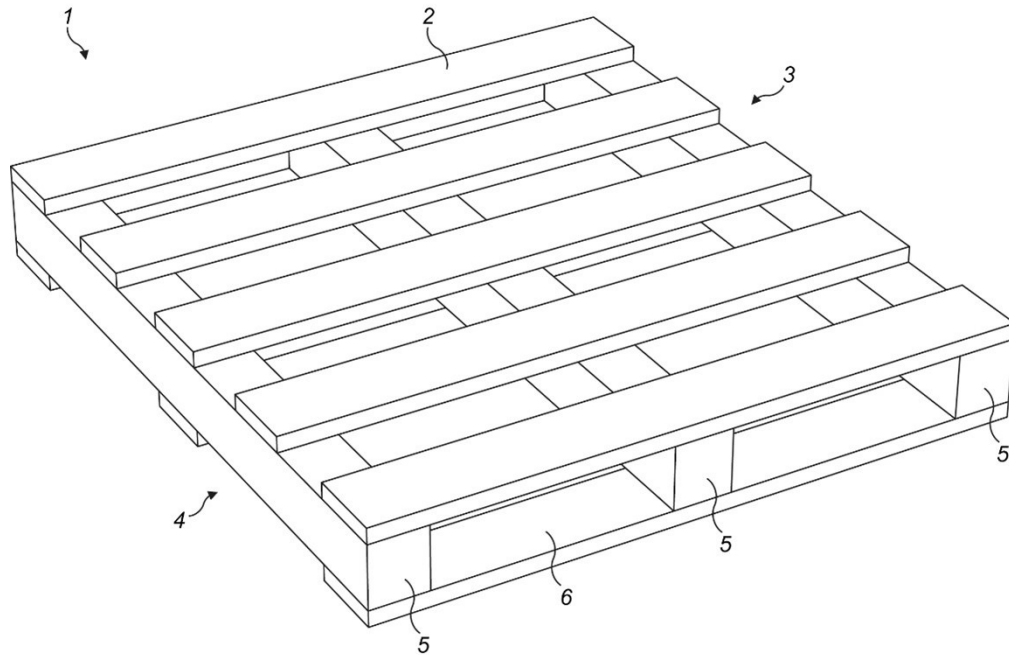

provisio

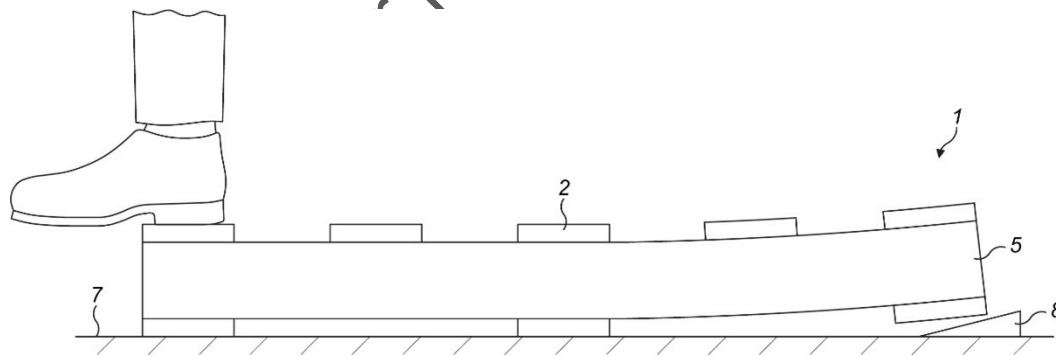

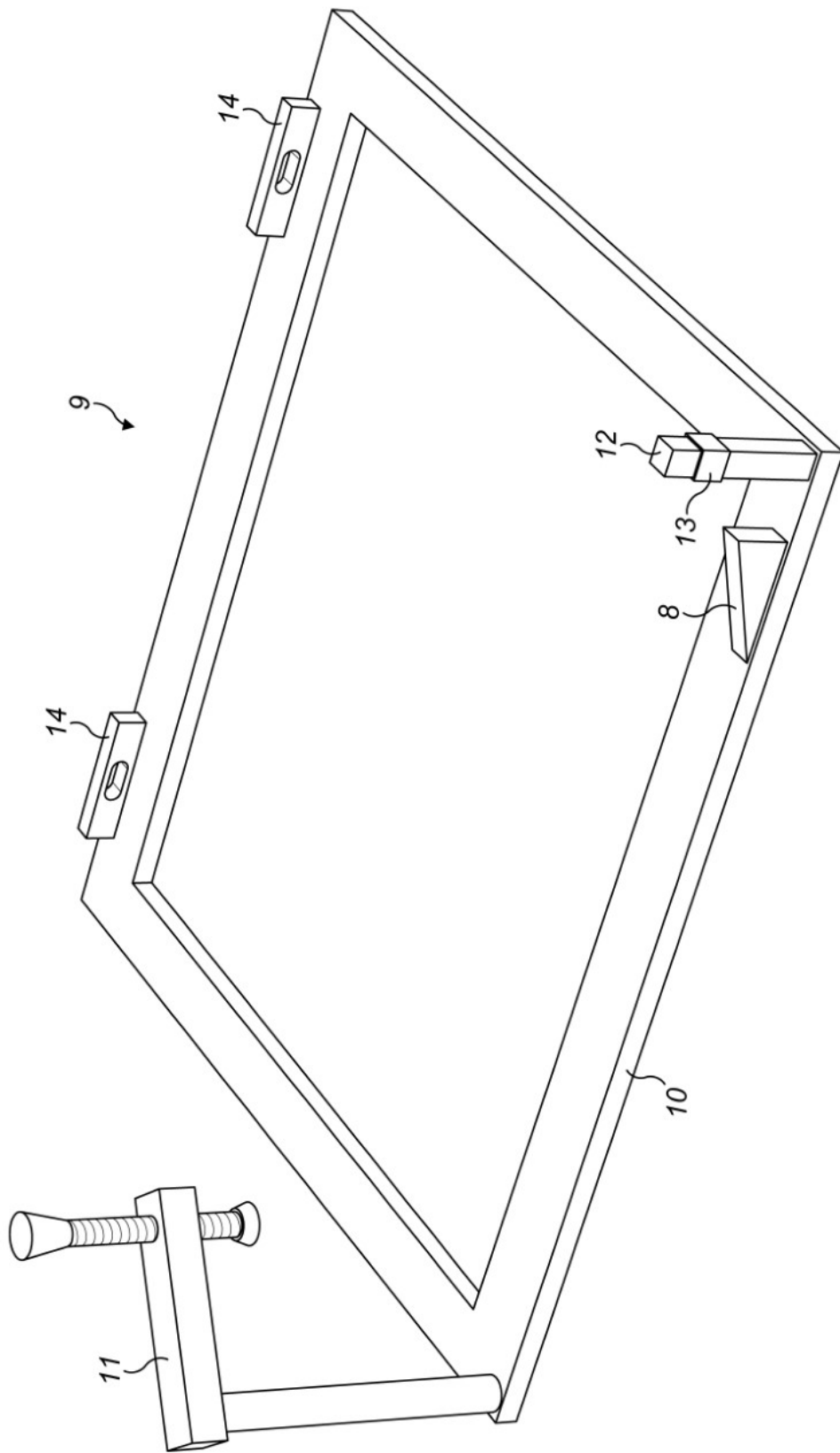
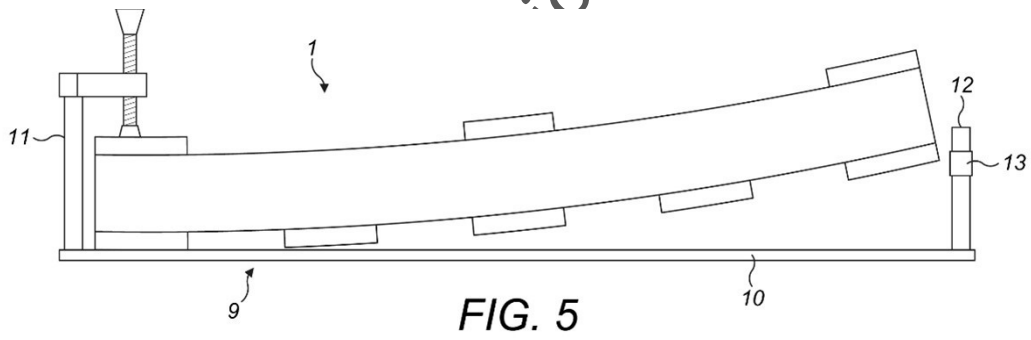
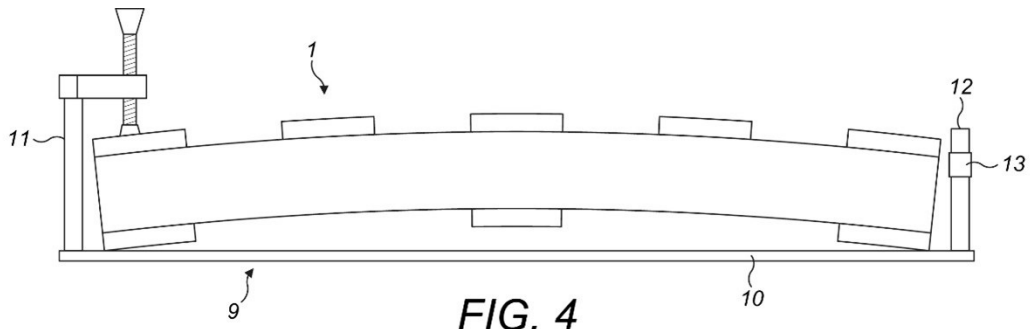

FIG. 3

rotation



Question

ional pending C